

SALTIX 10, SALTIX 10 C, ALTO 101D

Model:
SALTIX 10
SALTIX 10 C



Stückliste Deutsch

22-08-2011

Inhalt

SALTIX 10, SALTIX 10 C, ALTO 101D

Summary ALTO 101D, SALTIX 10 C	3
Summary SALTIX 10	5
Zubehör	7
EMPFOHLENE ERSATZTEILE	9

Summary ALTO 101D, SALTIX 10 C

SALTIX 10, SALTIX 10 C, ALTO 101D

22-08-2011

ET-Liste-Nr.
SALTIX1002

3

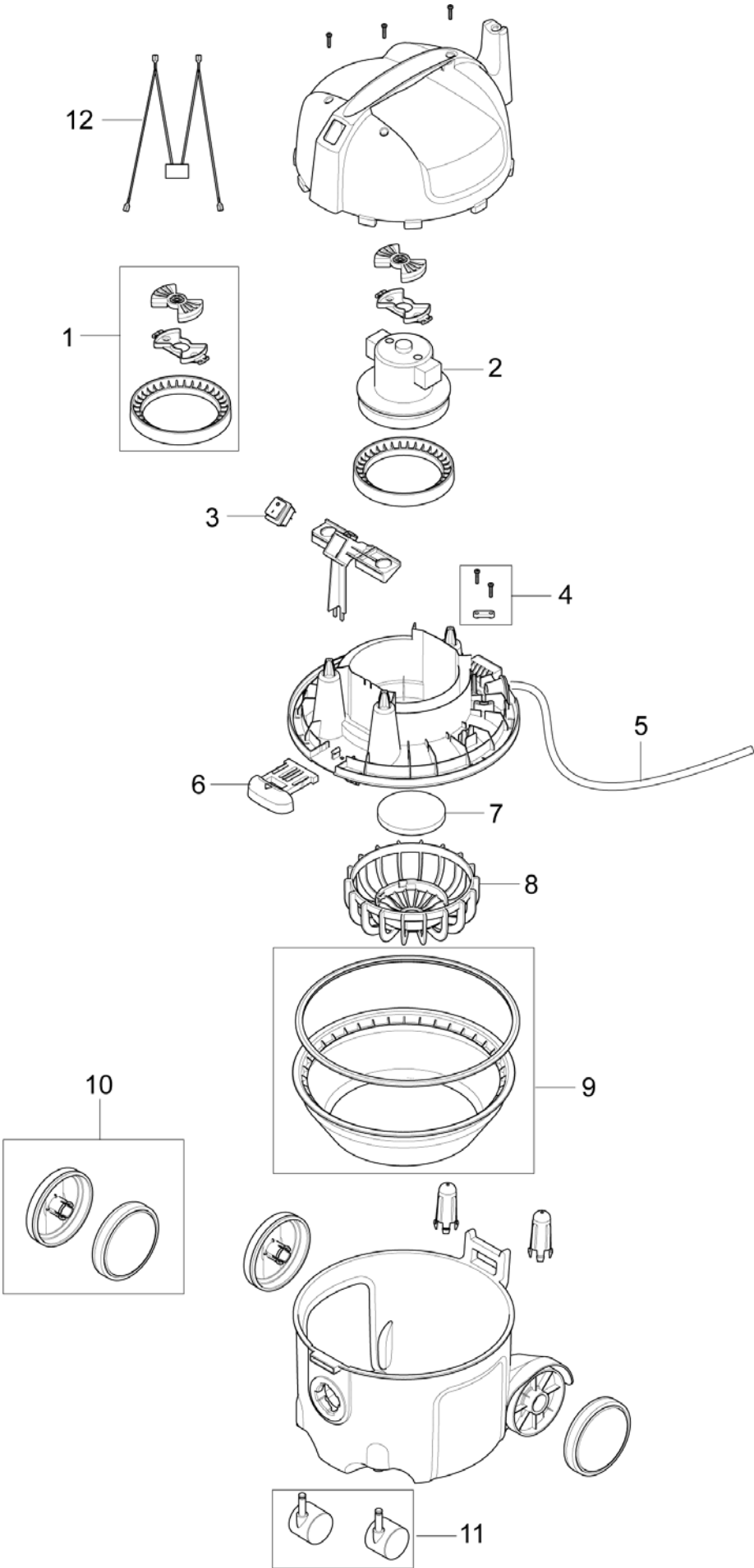

Summary ALTO 101D, SALTIX 10 C

SALTIX 10, SALTIX 10 C, ALTO 101D

22-08-2011

ET-Liste-Nr.
SALTIX1002

4

Pos	Artikelnr.	Me	Beschreibung	EAN
0		1	BOX VC300 HEPA EU1 AND SALTIX 10	5703887112
0	147 1436 000	1	BOX GD111 AND SALTIX 10	5703887110
1	147 0660 500	1	Motorhalterung	7319519652
2	147 1428 500	1	Motoreinheit 230v 900w	EU + CN 7319519673
3	140 9537 500	1	Schalter 2pol.	7319519639
4	140 6560 500	1	ANTI STRAIN CLIP	7319519640
5	140 6800 650	1	Kabel 10m EU	EU 7319519673
5	147 0504 540	1	CORD SET 10.5M CHINA	CN 7319519673
6	147 1409 500	1	Verschlussriegel	Grey 7319519673
7	147 0670 500	1	Motorfilterkit f. GD910	7319519651
8	147 0669 500	1	Filterstützkorb GD 910	7319519651
9	147 1432 500	1	Filtertuch kpl. (zw. Be- hälter + Motor)	Accessory 7319519673
10	140 8458 500	1	Räder, hinten (2) Kit f. UZ 932/934	7319519632
11	140 8445 500	1	Lenkrollenkit	7319519629
12	140 7620 530	1	Störschutz	7319519640

Summary SALTIX 10

SALTIX 10, SALTIX 10 C, ALTO 101D

22-08-2011

ET-Liste-Nr.
SALTIX1004

5

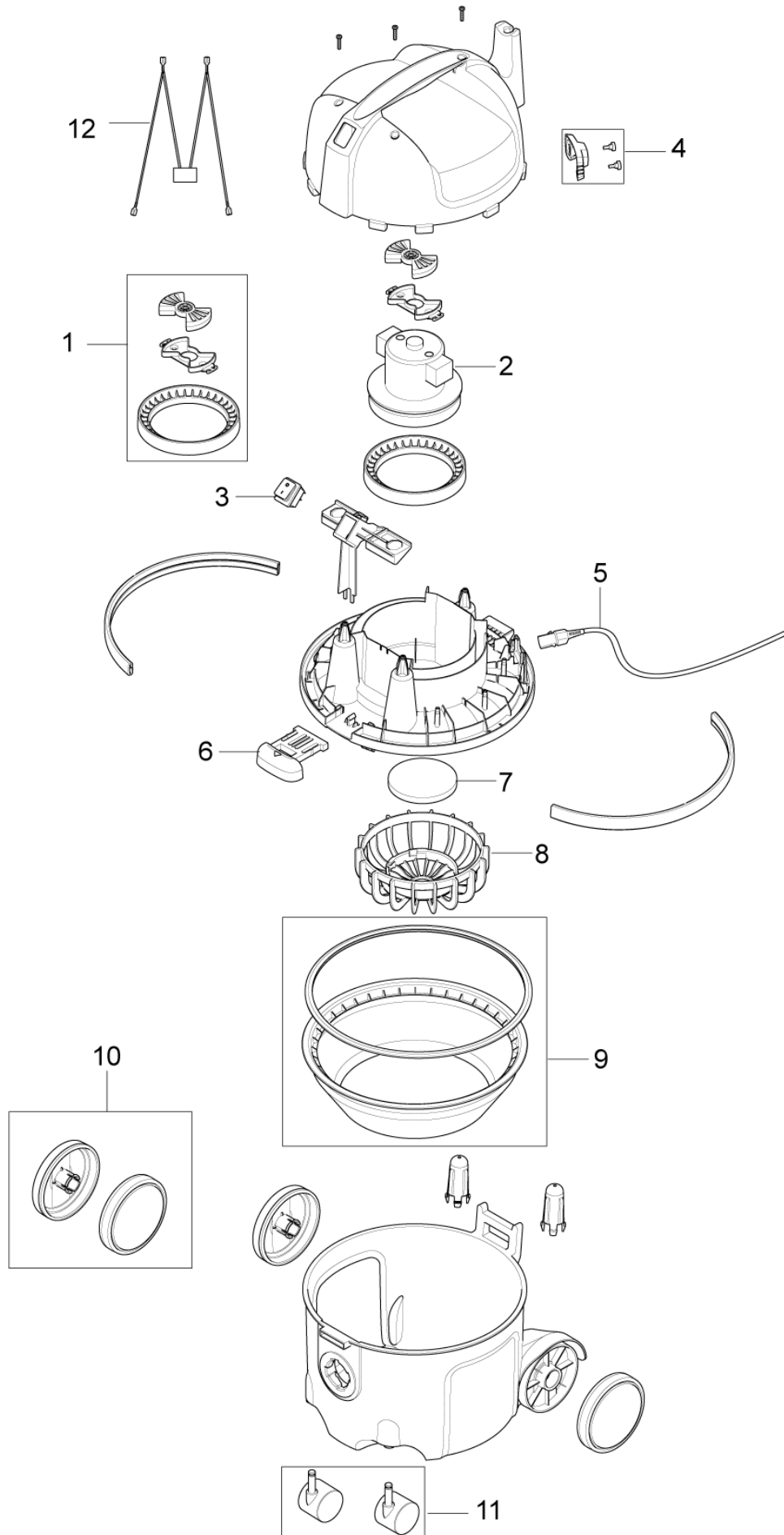

Summary SALTIX 10

SALTIX 10, SALTIX 10 C, ALTO 101D

22-08-2011

ET-Liste-Nr.
SALTIX1004

6

Pos	Artikelnr.	Me	Beschreibung	EAN
0		1	BOX VC300 HEPA EU1 AND SALTIX 10	5703887112
0		1	BOX KIT FOR THOR	5703887112
0	107403715	1	BOX KIT FOR ALTO	5703887112
0	147 1436 000	1	BOX GD111 AND SALTIX 10	5703887110
1	147 0660 500	1	Motorhalterung	7319519652
2	107402675	1	FAN UNIT 1200W TCO KIT	5703887110
3	140 9537 500	1	Schalter 2pol.	7319519639
4	107402674	1	CORD LOCK KIT	5703887110
5	107402676	1	Netzkabel 10m, abnehmbar	5703887110
5	107402901	1	Netzkabel 15m, abnehmbar	5703887112
6	147 1409 500	1	Verschlussriegel	Grey 7319519673
7	147 0670 500	1	Motorfilterkit f. GD910	7319519651
8	147 0669 500	1	Filterstützkorb GD 910	7319519651
9	147 1432 500	1	Filtertuch kpl. (zw . Be- hälter + Motor)	Accessory 7319519673
10	140 8458 500	1	Räder, hinten (2) Kit f. UZ 932/934	7319519632
11	140 8445 500	1	Lenkrollenkit	7319519629
12	140 7620 530	1	Störschutz	7319519640

Zubehör

SALTIX 10, SALTIX 10 C, ALTO 101D

22-08-2011

ET-Liste-Nr.
SALTIX1005

7

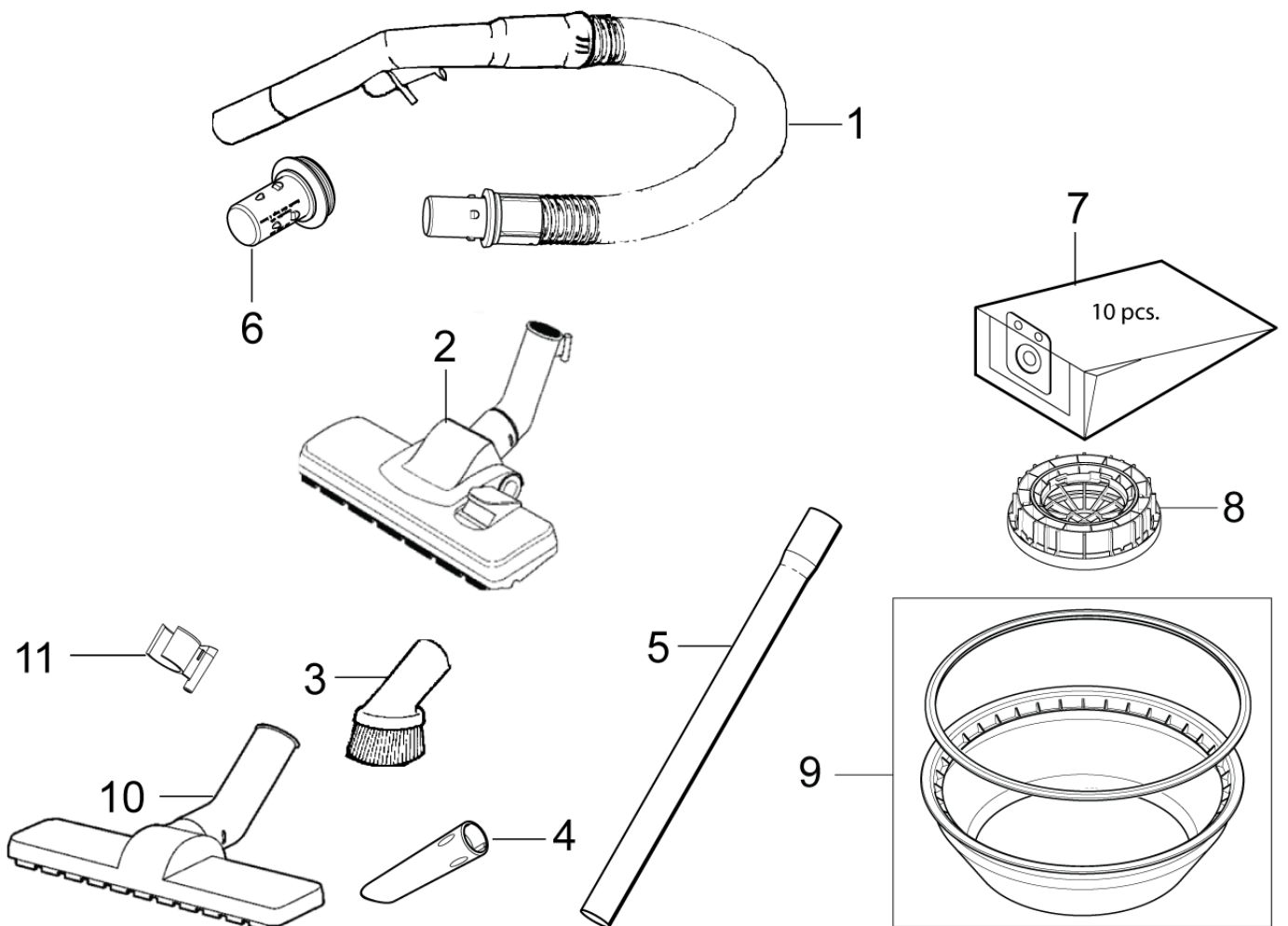

Zubehör

SALTIX 10, SALTIX 10 C, ALTO 101D

22-08-2011

ET-Liste-Nr.
SALTIX1005

8

Pos	Artikelnr.	Me	Beschreibung	EAN
1	147 0765 500	1	Saugschlauch konisch38/32 2m kpl. f. GD	7319519651
2	107403122	1	Bodendüse D32 (D252)	5703887113
3	140 8244 500	1	Bürstendüse, rund D32	7319519658
4	147 0146 500	1	Fugendüse D 32	7319519647
5	011 6431 500	2	Verlängerungsrohr Alu, 32mm/1x500mm	7319519631
5	140 8246 040	2	Stahlrohr 50cm f. Viking/ GD320/GWD335	7319519607
6	107401199	1	Numatic Adapter	5703887107
7	140 8618 000	1	Papiertüten 9l, 10er Pack f.GD1010/2000/Saltix3	7319519628
8	107402902	1	HEPA-Filterelement	ONLY SALTIX 10 5703887112
9	147 1432 500	1	Filtertuch kpl. (zw. Be- hälter + Motor)	7319519673
10	140 6700 540	1	Hartbodendüse 32mm	7319519636
11	147 0585 500	1	Verstauklemme schw arz	7319519648

EMPFOHLENE ERSATZTEILE

SALTIX 10, SALTIX 10 C, ALTO 101D

22-08-2011

ET-Liste-Nr.
SALTIX1008

9

Keine Zeichnung zur ET-Liste

EMPFOHLENE ERSATZTEILE

SALTIX 10, SALTIX 10 C, ALTO 101D

22-08-2011

ET-Liste-Nr.
SALTIX1008

10

Pos	Artikelnr.	Me	Beschreibung		EAN
0	107402674	1	CORD LOCK KIT	SALTIX 10	5703887110
0	107402675	1	FAN UNIT 1200W TCO KIT	SALTIX 10	5703887110
0	107402676	1	Netzkabel 10m, abnehmbar	SALTIX 10	5703887110
0	140 6560 500	1	ANTI STRAIN CLIP		7319519640
0	140 6800 650	1	Kabel 10m EU	101D	7319519673
0	140 7620 530	1	Störschutz		7319519640
0	140 8445 500	1	Lenkrollenkit		7319519629
0	140 8458 500	1	Räder, hinten (2) Kit f. UZ 932/934		7319519632
0	140 9537 500	1	Schalter 2pol.		7319519639
0	147 0504 540	1	CORD SET 10.5M CHINA	SALTIX 10C	7319519673
0	147 0660 500	1	Motorhalterung		7319519652
0	147 0669 500	1	Filterstützkorb GD 910		7319519651
0	147 0670 500	1	Motorfilterkit f. GD910		7319519651
0	147 1428 500	1	Motoreinheit 230v 900w	101D, SALTIX 10C	7319519673
0	147 1432 500	1	Filtertuch kpl. (zw. Be- hälter + Motor)		7319519673
0	147 1436 000	1	BOX GD111 AND SALTIX 10		5703887110